

Concealed Fast Fix Shower Fitting Kit

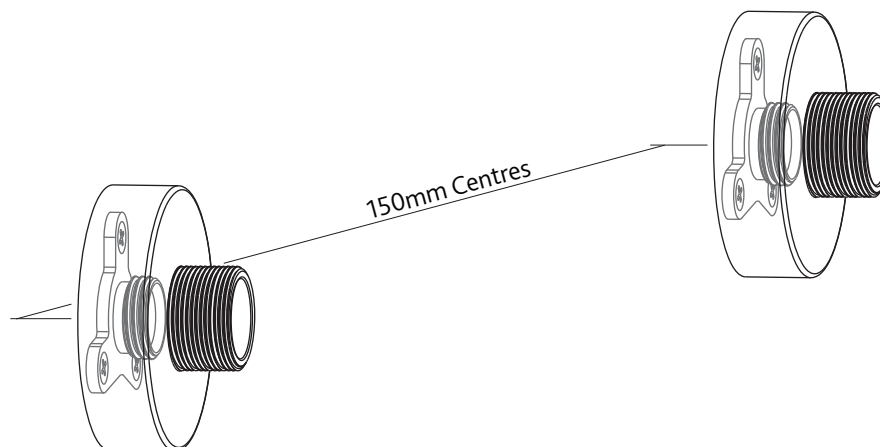

Description

The concealed fast fix kit is designed for surface mounting on a tiled wall or water resistant surface as part of a cavity or solid wall.

The purpose is to provide a secure fixing for a bar shower and to provide hot and cold water supplies to the shower.

The water connection for each bracket is designed for concealed pipework hidden in a cavity or solid wall.

The inlet connection to both fixings is 15 mm compression to BS EN 1254, for use with half hard R250 copper tube to BS EN 1057, and the outlet connection is a ¾" external pipe threads to BS EN ISO 228.

Installation

Carefully follow these instructions and ensure that the installation conforms to the Water Regulations.

The method of concealing the hot and cold supply pipes and how the concealed fixings are to be mounted should be planned carefully before installation commences.

The bar shower is normally mounted 1.1 to 1.2m above the floor of the shower area but can be mounted higher if required.

The distance between the inlet ports of most bar showers is 150mm but this should be checked on the actual shower before commencing.

Check that all the components are available before commencing installation.

The concealed fixings should ideally be mounted utilising any support structure in the cavity wall or if unavailable it is recommended that a plywood pad is incorporated into the structure to support the shower valve.

Use the plastic wall plugs supplied which are suitable for securing the brackets to a solid wall.

To secure to plaster board suitable wall plugs must be used (not supplied) but are readily available at DIY stores.

Installation Continued

The supply pipes to the concealed fixings can be from below, above or the side to suit site conditions.

Check which is the hot supply to the bar shower when facing the shower, normally hot is on the left hand side.

Cavity wall

Cut 2 holes in the plaster board 18mm in diameter at 150mm centres at the desired height. Using the wall plate as a template mark the position of the 3 fixing holes.

Drill 3 holes for the fixing screws and fit the 3 plastic plugs.

If drilling into ceramic tiles use a ceramic bit.

To avoid cracking the tiles ensure the wall plugs are pushed all the way behind the ceramic tile.

Repeat for the second bracket.

Make up 2 supply pipes using a solder elbow as shown and feed them down or up the cavity and guide the ends of the pipes through the 2 holes.

The supply pipes must protrude from the finished wall by 23 to 28mm, the length of the pipe can be shortened prior to assembly if required.

Solid wall

Chase two channels into the wall for the two supply pipes at 150mm centres, ensuring that the pipes and bends are fully embedded.

Using the wall plate as a template mark the position of the 3 fixing holes as shown, ensuring the concealed fixing is level.

Drill 3 holes for the fixing screws and fit 3 plastic plugs.

Repeat for the second bracket.

Fill the pipe channels and finish plastering the wall, the copper pipe must protrude from the finished tiled wall by between 23 to 28mm.

Finish tiling the wall noting the position of the 6 fixing plugs.

Concealed Fast Fix Shower Fitting Kit

Dimensions and Components

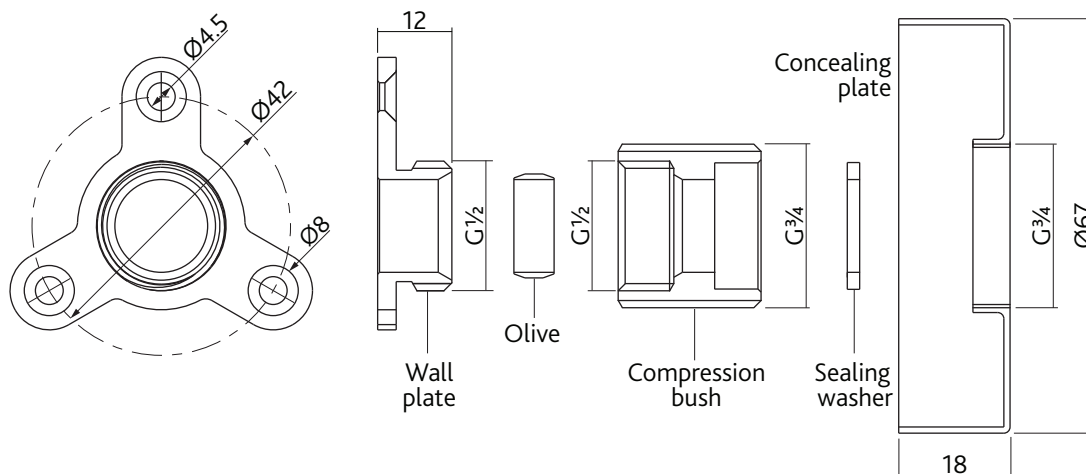

Typical Assembly

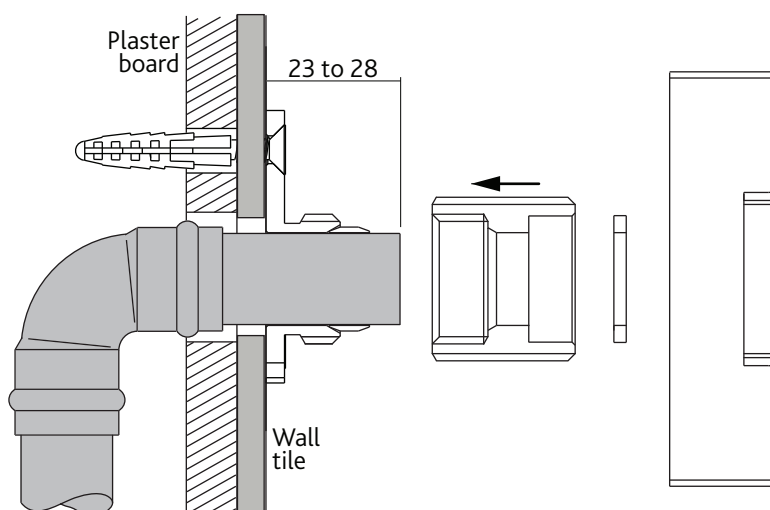

All dimensions in mm unless otherwise stated

Fitting the Wall Plates and Assembly

Apply silicone sealer to the back of the wall plates and seal between the copper pipes and the wall to prevent water entering the cavity.

Fit the wall plates to the 2 protruding copper pipes, press to the wall and secure with the 6 chrome plated counter sunk screws.

Fit the olives and compression bushes, initially hand tighten before final tightening using a suitably sized spanner on the 2 flats to make water tight joints. Care must be taken not to damage the chrome finish on the compression nuts.

Add a bead of sealant to the inner edge of each concealing plate before screwing onto the compression bushes.

The mounting brackets are now ready to accept the bar shower.

Fit bar shower (not supplied) using the sealing washers, turn on the water supplies and check that all joints are water tight.

Aftercare

To maintain the appearance of the concealed plate periodically they should be cleaned with a soft damp cloth and a mild detergent before rinsing.

© Patents & Design Altecnic 2019

Altecnic Ltd retains all rights (including patents, designs and copyrights, trademarks and any other intellectual property rights) in relation to all information provided on or via the website, brochures or any other documents, including all texts, graphics and logos, contained on the website, in brochures or in any other documents published in the name of or on behalf of Altecnic Ltd in any form, without prior written consent of Altecnic Ltd.

Altecnic Ltd Mustang Drive, Stafford, Staffordshire ST16 1GW

T: +44 (0)1785 218200 E: sales@altecnic.co.uk

Registered in England No: 2095101

altecnic.co.uk

IOM 145 01-11-19

E & O.E

© Altecnic Limited. 2019

ALTECNIC™

altecnic